



For Walleting

Surgical Gloves
Procedure Packs
Suction Catheter Kits

Doyen's GPM System is custom built to comply with the needs of the surgical market.

Benefits

- Up to 80 pairs of gloves per minute
- In-line flexographic printing of wallet
- Complies with the industry standard for maintenance of sterility in use
- Processes crepe and hard kraft walleting materials
- Fully validated, GMP, CE and OSHA compliant
- Optional AGPM unit, an online cuffing system that automatically handles glove placement, reducing labor and wastage by eliminating improperly placed gloves.
- A link to a HDW pouching machine is possible

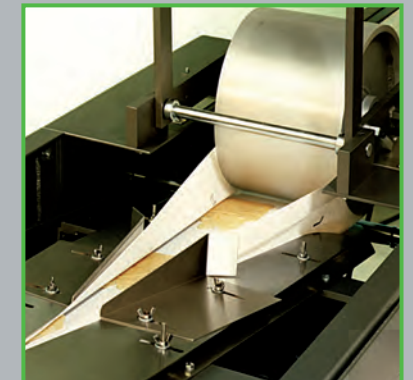

Glove Walleting System - GPM



TECHNICAL INFORMATION

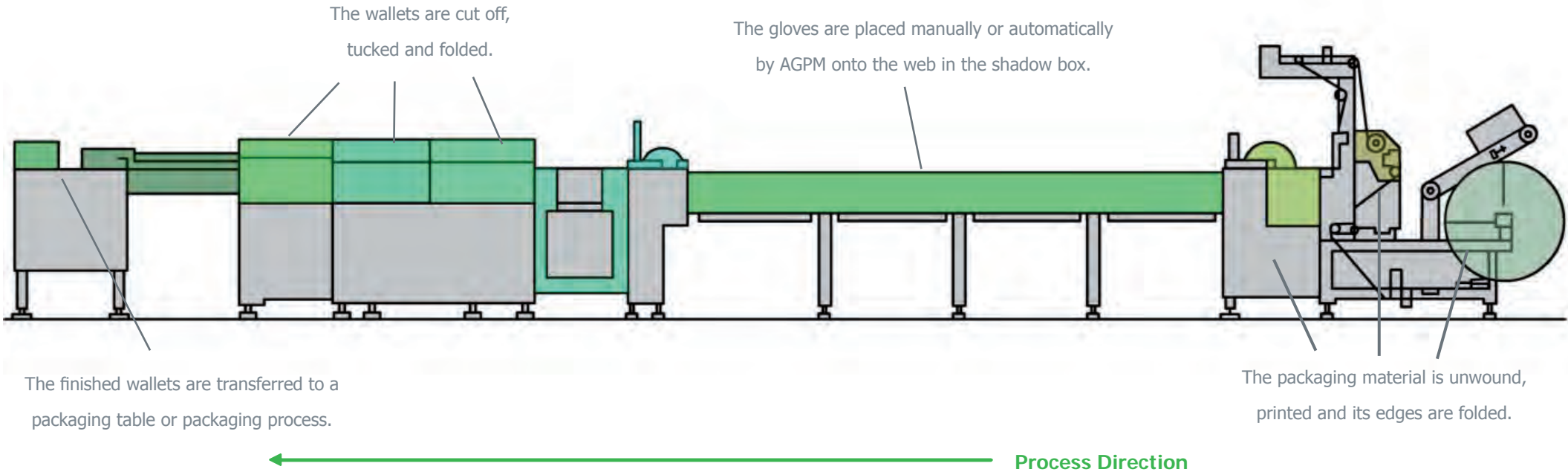

Model	GPM
Wallet length	200mm - 229mm
Wallet width	100mm - 125mm
Speed	Up to 80 wallets / minute
Web Roll Spec	76mm core 1000mm diameter max.
Dimensions (ca.)	L 10700mm x W 1000mm x H 1800mm
Weight (uncrated)	3000kg

Doyen Medipharm Ltd
 Gateway 11 Business Park, Copper Smith Way,
 Wymondham, Norfolk, NR18 0WY, UK
 Tel: (+44) 01953 600078 - Fax: (+44) 01953 605069
 sales@doyenmedipharm.co.uk

Doyen Medipharm LLC
 4030 South Pipkin Road, Suite 102,
 Lakeland, Florida 33811, USA
 Tel: (+1) 863-683-6335 - Fax: (+1) 863-683-6857
 salesUS@doyenmedipharm.com

Doyen Medipharm Ltd
 5008 Jalan Lunas, First Floor, Batu 2 1/2
 Kulim, Kedah Darul Aman, Malaysia
 Tel: (+604) 495 1619 - Fax: (+604) 495 1697
 Surren@DoyenMY.com



www.doyenmedipharm.com

Europe
 North and South America
 Asia